

Di-VentiX II™

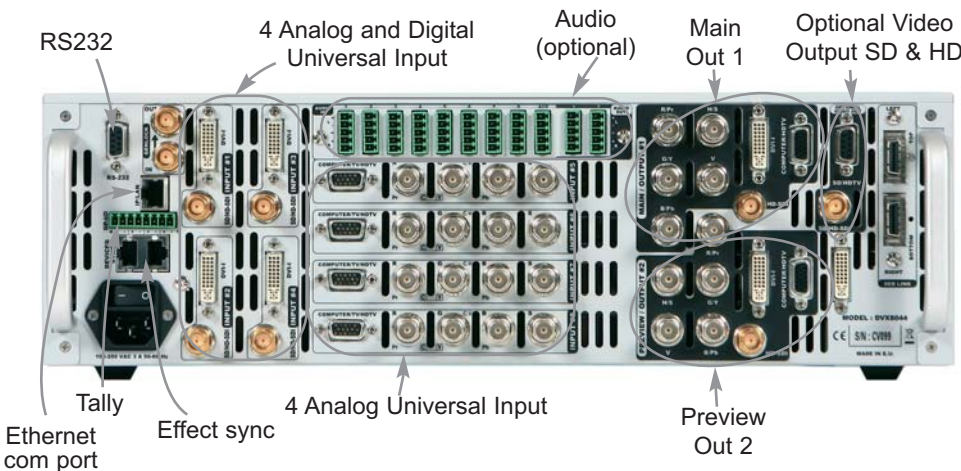

Ref: DVX8044

Multi Layer Hi-Resolution Mixer Scaler Seamless Switcher with Keying / Edge Blending system with 4 Scalers

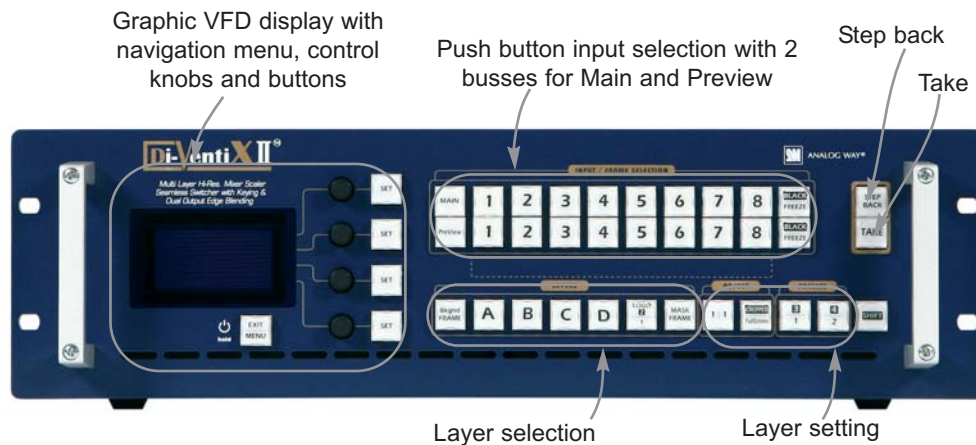

References

- DVX8044: Di-VentiX II
- DVX8044-A: Di-VentiX II with Audio Switcher Option
- DVX8044-VO: Di-VentiX II with Video Output Option
- DVX8044-VO-A: Di-VentiX II with Video Output and Audio Switcher Options
- CBD-8044: Cross Blender II for DVX8044 (included)

Options

- OPT-8044-A: Audio Switcher Option
- OPT-8044-VO: Video Output Option

Cables for Di-VentiX II

- > 1.8m/6ft to 20m/66ft BNC Cables
- > 1.8m/6ft to 20m/66ft S.Video Cables
- > 0.5m/1ft to 30m/100ft Remote Cables
- > 3m/10ft to 30m/100ft SDI-HD SDI Cables
- > 1.8m/3ft to 70m/230ft DVI Cable
- > 0.5m/1ft to 1.8m/6ft VGA Cable

To Control Di-VentiX II

- Remote Control Software (supplied)
- ARC100: Axion
- ORC50: Orchestra
- RKD8044-T: Remote Keypad With T-Bar
- RKD8044: Remote Keypad without T-Bar
- AMS100: Axion Manager - Show control software

Axion



Orchestra



Inputs

- 4 Universal Analog and Digital Inputs:
- 4 Universal Analog Inputs
- SDTV, EDTV, HDTV and Computer formats up to 2K
- SD/HD-SDI and DVI
- Full Digital In/Out Processing

Outputs

- 2 Analog and Digital Outputs: Main & Preview
- HDTV and Computer Formats up to 2K
- RGBHV, DVI and HD-SDI
- Optional Video Output: SD/HD-TV Analog and Digital

Operation Modes and Effects

- 3 Operation Modes: Mixer, Sync Matrix and Edge Blending
- 4 Live Layers
- 8 Full Frames, 8 Logo Memories
- Luma Keying / Chroma Keying
- 16/9, 4/3, special sized and cropped output
- Pan & zoom resizing up to 1000%
- Dissolve, Slide, Transparency
- Moving PIPs
- Numerous Image Borders

* can be used simultaneously when the format is compatible

Additional features

- RS232 and Ethernet Port for Control or Upgrade
- Remote control software
- Optional Integrated Audio Stereo Switcher

High Resolution Mixers and Seamless Switchers

Technical Specifications

8 Universal Inputs

Analog Inputs (All inputs #1 to #8)

- SD-TV** • Composite, S.Video, YUV, RGBS or RGBS
 - NTSC: 15.735kHz / 60Hz
 - PAL/SECAM : 15.625kHz / 50Hz

ED/HD-TV

- RGBS, RGBS or YUV
 - 480p / 60 Hz – 576p / 50 Hz - 720p, 1080i, 1035i / 50 or 60Hz – 1080p / 24, 25, 30, 50 or 60 Hz – 1080psF / 24, 25 or 30 Hz

Computer

- RGBHV, RGBS or RGBS
 - Resolution up to 1600x1200 / 60 Hz, 1920x1200 / 60 Hz or 2048x1080 / 60 Hz
 - Horizontal frequency from 31.5 to 130 kHz
 - Vertical frequency up to 130 Hz
 - FpxMax = 165MHz

Digital Inputs (Inputs #1 to #4 only)

- DVI-D: SD-TV, ED-TV, HD-TV and Computer formats
- SDI: SD-TV & HD-TV – YUV / 10bits / 4:2:2
- Automatic synchronization detection

Main and Preview Outputs

Computer Digital and Analog

- RGBHV, RGBS or RGBS and DVI
 - Resolution up to 1600x1200 / 60 Hz, 1920x1200 / 60 Hz or 2048x1080 / 60 Hz
 - Vertical frequency 50, 60, 72 or 75 Hz depending on Output format
 - FpxMax = 165MHz

HD-TV

- RGBS, RGBS or YUV, DVI and HD-SDI
 - 720p, 1080i, 1035i / 50 or 60Hz – 1080p / 24, 25, 30, 50 or 60Hz – 1080psF / 24, 25 or 30 Hz

Optional Video Outputs

- Analog and Digital SD/HD-TV
- SD-TV: NTSC/PAL, S.Video, RGB/YUV, DVI-D and SDI
- HD-TV: RGB/YUV, DVI-D and HD-SDI
- HD Formats: 720p, 1080i / 50 or 60Hz – 1080p / 24, 25, 30, 50 or 60 Hz – 1080psF / 25 or 30 Hz (1080p / 50 and 60 Hz is not available in HD-SDI)

Analog Genlock

- Input: HD Black 3 levels or Black Burst
- Output: Active loop through

Optional Audio Stereo In/Out

- **Inputs:** - 8 Audio stereo inputs + 1 Auxiliary
 - Balanced/Unbalanced
 - Vi = +18dB
 - Zi = 20 kOhms (Unbalanced) / 40 kOhms (Balanced)
 - Adjustable Level per input
- **Outputs:** - 2 independent outputs
 - Balanced/Unbalanced
 - Vo = +18 dBu / 300 Ohms (Unbalanced)
 - Vo = +24 dBu / 600 Ohms (Balanced)

User Controls - Front Panel

- Standby On/Off
- Input, Layer and Logo direct access
- Freeze/Black
- User defined layer properties
- Aspect ratio: 1/1 – Cropped - Full Screen
- Large Graphic VFD screen with control knobs and buttons for easy and fast access to menus and adjustments

Connectors - Rear Panel

- **Input #1 to #4 Connectors:**
 - DVI-I Female: (Digital and Analog SD/ED/HD-TV and Computer)
 - BNC (SD/HD-SDI)
- **Input #5 to #8 Connectors:**
 - HD15-F and 4xBNC: (Analog SD/ED/HD-TV and Computer)

Di-VentiX II™ by Analog Way is a Multi Layer Mixer Scaler Seamless Switcher with Universal Analog and Digital input/output and Full High Resolution Digital Processing. It offers numerous Live effects including Keying and Moving PiP as well as 3 different operation modes: Multi Layer Mixer, Stand alone Embedded Edge Blending and 8 by 2 Seamless Sync Matrix.

Multi Layer Mixer Mode

Di-VentiX II uses one output as a Preview and the other, the Main output, for the audience. The Preview allows viewing 100% of what the Main output will display. Thanks to its full frame and logo memory, the **Di-VentiX II** can display up to 6 layers: 4 Live Sources, 1 Frame, 1 Logo. Live Layers can be customized by the users with various attributes: Borders, Movements, Keying or Transparency... Full screen Frame can be used as a background.

Seamless Sync Matrix Mode

Di-VentiX II offers a 8 x 2 scaled matrix with true seamless switching. The switch between any of the 8 inputs can be in cut or fade and synchronized on the 2 outputs. Frame and Logos are also available.

• Main and Preview Output Connectors:

- Each output is fitted with:
 - DVI-I Female: (Digital and Analog) RGB or YUV
 - HD15 Female: RGB or YUV
 - BNC : HD-SDI
 - BNC (x5): RGB or YUV
- **Miscellaneous:**
 - BNC (x2): Analog Genlock In and Loop Out
 - RJ45 (x2): Proprietary Device Synchronization

Connectors - Rear Panel continued

- MCO 8 pins: GPI/O
- DB9: RS232 for remote control
- RJ45: Ethernet connection
- AC mains connector with On/Off switch
- **Optional Video Out:**
 - DB9-F: NTSC/PAL, S.Video, SD/HD-RGB/YUV
 - BNC-F: SD/HD-SDI
 - DVI-D-F: SD/HD-TV
- **Optional Audio:**
 - 5 pins MCO connectors: 9 for Inputs and 2 for Outputs

Dimensions: 3U, 19"

- D 16.5" x W 19" x H 5.25"
- D 420 mm x W 480 mm x H 133 mm

Weight: 6.5kg / 14.3lbs

Power Supply

- Internal, universal, automatic, 100-250 V; 50/60 Hz; 250 W (UL, CSA, GS, CE)

Supplied with

- 1 x AC power cable
- 1 x Remote control software
- 1 x User manual

Warranty

- 3 year warranty on parts and labor back to factory

Specifications subject to change without prior notice

Embedded Edge Blending Mode

Di-VentiX II provides a stand alone 2 projector large blended screen horizontally or vertically. In this configuration the **Di-VentiX II** offers the same functions as in Multi Layer Mixer Mode. Since the 2 outputs are used for the audience display, the optional Video Out can be used as a True Preview Monitor making the control of the shows as easy as in standard Mixer Mode.

General Features

The **Di-VentiX II** offers 8 universal analog inputs including 4 fitted with digital DVI and SDI. SDI is compatible with SD and HD TV formats so is DVI which offers computer formats in addition. With state of the art 100% digital processing, the **Di-VentiX II** outputs Digital and Analog Signals in SDI, DVI and VGA (RGBHV) simultaneously with a selection of many formats from HDTV to Computer 2K. **Di-VentiX II** provides a high image quality thanks to its true 10 bits SD/HD auto adaptive pixel by pixel 3D motion compensation processing, de-interlacing, auto 3:2 and 2:2 reverse pull down circuitry and processing, TBC and Frame follower. GPI/O interface can be used through Tallies.

LOGO and FULL FRAME can be recorded in the large non volatile memory of the **DVX8044**: 8 still logos and 8 full screen frames.

Audio Stereo switcher card (optional) features 8 inputs and 2 outputs. An auxiliary input can be mixed with any other input. Master volume and individual input level can be adjusted. Each input and output offers balanced or unbalanced connections.

Video Output card (optional) provides SD or HD TV formats in various signals and connectors from Composite Video to HD SDI. This output can be used to record the show by outputting the same contents as the Main output or to dispatch the Preview image on video monitors. In addition, it can be used as a real Preview output in case of Sync Matrix or Embedded Edge Blending Mode.

Multi-Screen Edge Blending can be achieved by linking multiple **Di-VentiX II** updated with the **Cross Blender II** option (included). Each **Di-VentiX II** used in Mixer Mode drives one video projector to create extra large image up to 16 projectors horizontally or vertically.

Di-VentiX II is a high grade easy to use A/V Presentation Mixer Switcher particularly adapted to Rental and Staging due to its excellent versatility. Fully controlled from its own front panel as well as from the powerful **Axion** or the new **Orchestra** remote consoles and computer software, it offers a large range of utilization. Equipped with TCP/IP and RS232, **Di-VentiX II** can be updated with new features and functions improving its life time.

Analog Way France

- Phone: (33) 1 64 47 14 14
- Fax: (33) 1 64 47 14 73
- E-mail: saleseuro@analogway.com

Analog Way Inc. New York

- Phone: (212) 269 1902
- Fax: (212) 269 1943
- E-mail: salesusa@analogway.com

Analog Way Pte Ltd. Singapore

- Phone: (65) 6292 5800
- Fax: (65) 6292 5205
- E-mail: sales@analogwayasia.com



ANALOG WAY®